

Power When You Need It- Anytime, Every Time.

TWIN DG Set 500 kVA & 640 kVA

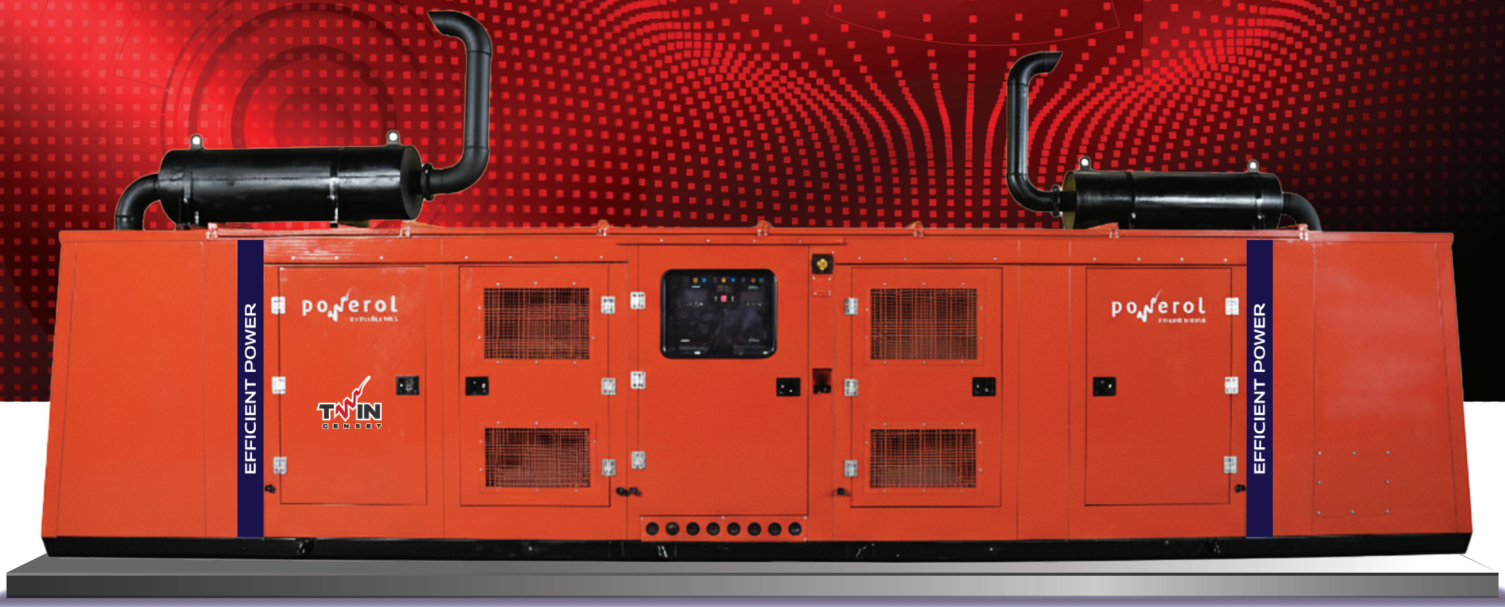

Highest
Reliability



Advanced
Synchronization
Technology



Eco Smart
Fuel Efficiency



Customizable
Load Handling

TWIN - Designed as per Use

The Twin Genset is a unique, innovative solution designed to optimize generator output to match actual load requirements. When you're running multiple machines or HVAC systems, you can deploy it in parallel or single-engine mode. Unlike conventional gensets which must run at full capacity even when demand is low the Genset automatically adjusts its output to the precise load, 24 hours a day. Its intelligent synchronization technology ensures both engines share the workload evenly & maximizing fuel efficiency.

APPLICATIONS



Unmatched reliability through dual power architecture: -

Twin Genset technology revolutionizes power generation by providing inherent redundancy and enhanced operational security. Our dual-unit configuration ensures continuous power availability, even during maintenance or unexpected component issues.

Superior Performance Advantages

Enhanced Load Management

- Intelligent load distribution across twin units
- Optimal fuel efficiency through selective operation

Operational Flexibility

- Scalable power output to match demand fluctuations
- Reduced operational costs through optimized fuel consumption

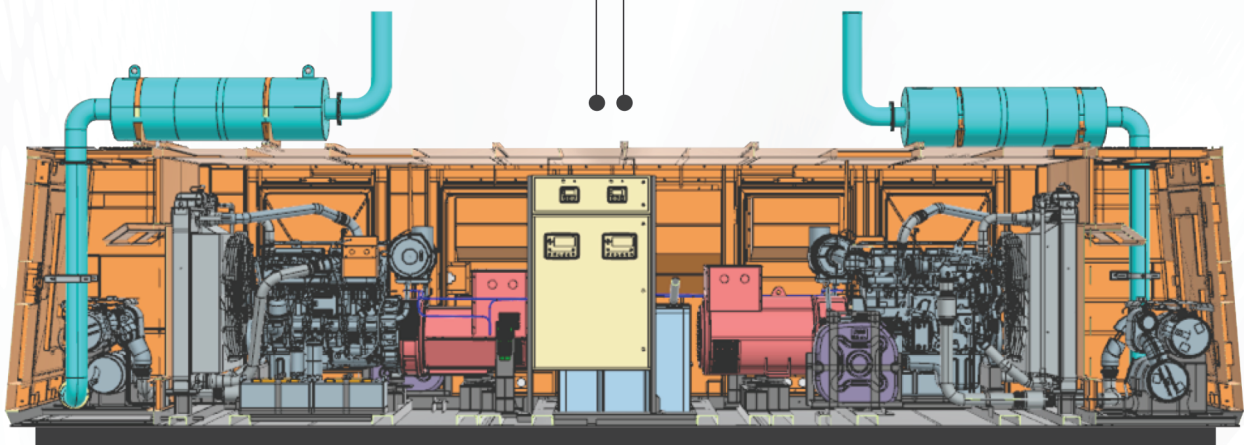

Maximum Uptime Assurance

- Automated failover capabilities ensure uninterrupted service
- Predictive maintenance scheduling minimizes downtime

Environmental Excellence: Reduced Carbon Footprint

- Advanced emission control systems across both units
- Optimized combustion technology for cleaner operation

Sustainable Operation

- Intelligent power management reduces fuel consumption
- Modular operation allows for energy-efficient partial load operation
- Extending Service Life: Reducing Maintenance and Environmental Impact.

Economic Benefits & Cost Optimization

- Lower total cost of ownership through extended equipment life
- Reduced maintenance expenses with load sharing
- Improved fuel efficiency translates to operational savings

Key Performance Advantages & Benefits:



Designed for applications with fluctuating power need



Twin gensets address multiple issues with reduction in fuel consumption and reduction in CO₂ emissions up to 40%



Lower Cost of Ownership



Reduction in downtime by having redundancy



Better performance in non-linear load



Higher motor starting capability

Existing DG design to be made applicable on 2X250 & 2X320kVA

Controller Used in Twin DG Set



+

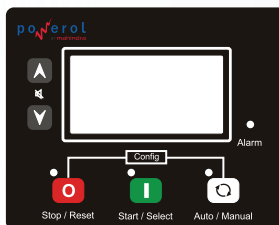

Logic Behind Twin DG set

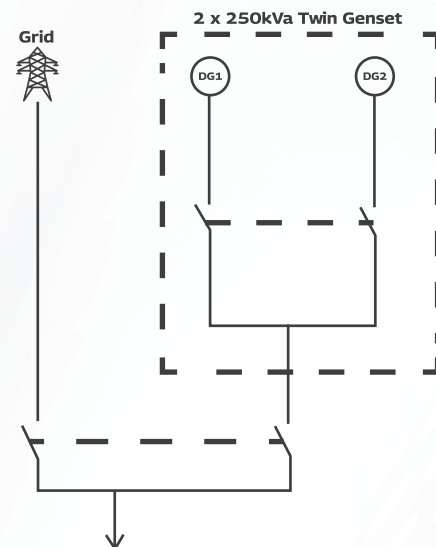

Technical Excellence

Our Twin Genset systems incorporate advanced control algorithms, real-time monitoring capabilities, and intelligent synchronization technology to deliver unparalleled performance reliability. Each unit is engineered to complement the other, creating a cohesive power generation ecosystem that exceeds traditional single-unit limitations.

Choose Twin Genset for power generation solutions that prioritize reliability, efficiency, and environmental responsibility while delivering exceptional long -

Remote Monitoring System

- RMS is standard scope above 75 kVA IOT incorporated for continuous remote monitoring of engine operational parameters like running hours, health, RPM, logs of the error and operational parameters through app and web - based platforms
- Helps in monitoring of generator or entire fleet of generators from anywhere, any time ensuring good health and efficiency of the generator
- Can be available for other range also if required

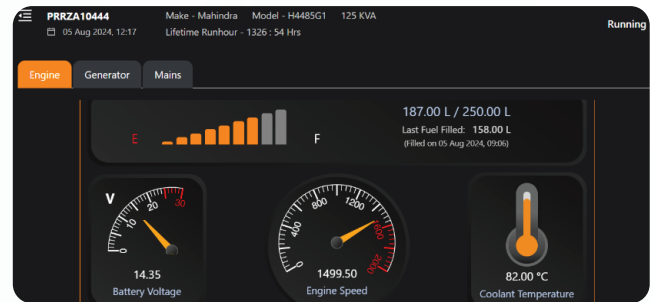

Smart Generator Management Solutions

- Receive timely notifications for maintenance checks (A Check/B Check), ensuring you never miss a critical service moment
- Tailor preventive maintenance schedules to the specific needs of your generators, enhancing their efficiency and reliability
- Automate maintenance tasks to stay ahead of potential issues, minimizing downtime and prolonging equipment lifespan
- Keep track of each fueling event to ensure accuracy and deter theft
- Examine fuel consumption patterns to pinpoint inefficiencies and improve fuel efficiency
- Boost operational transparency with our generator fuel traceability system, enabling precise fuel tracking and management

Optional Accessories

Cold Starting System | PMG | RTD | BTM | Space heater | External AVR

TECHNICAL SPECIFICATIONS

Genset Rating (kVA)	500	640
Genset Model No.	MT500DR	MT640DR
Duty (Stand By/ Prime)	Prime	Prime
Power Rating (kW)	400	512
No. of Phases	3	3
Output Voltage (V)	415	415
Power Factor (lagging)	0.8	0.8
Current (A) (3 Phase)	695	889.6
Frequency (Hz)/ RPM	50/1500	50/1500
Governing Class	G3/G2	G3/G2
Starting System	24 V	24 V
Fuel Tank Capacity (lit)	780	780
DEF Tank Capacity (lit)	50 + 50	50 + 50
Genset Dimension (LxWxH) (mm) Approx.	8800 X 1600 X 1975	8800 X 1600 X 1975
Engine Specifications		
Make	Mahindra & Mahindra Ltd.	Mahindra & Mahindra Ltd.
Model	H6935G1	H6935G2
Type	Electronic	Electronic
Rated Power Output (Hp)	620	780
Aspiration	TCIC	TCIC
No. of Cylinders	6 x 2	6 x 2
Bore x Stroke (mm)	116.6 X 146.1	116.6 X 146.1
Displacement (Ltr)	9.3 x 2	9.3 x 2
Total Lube Oil capacity (lit)	35 x 2	35 x 2
Lube Oil Change Period (hrs.)	500Hrs	500Hrs
System Coolant Capacity (lit)	31 x 2	31 x 2
Alternator Specifications		
Make	CG/LS/Stamford/Equivalent	CG/LS/Stamford/Equivalent
Enclosure Type	IP23	IP23
Volatge Regulation	+/- 1%	+/- 1%
Class of Insulation	H	H
Maximum Unbalanced load across Phases	25%	25%

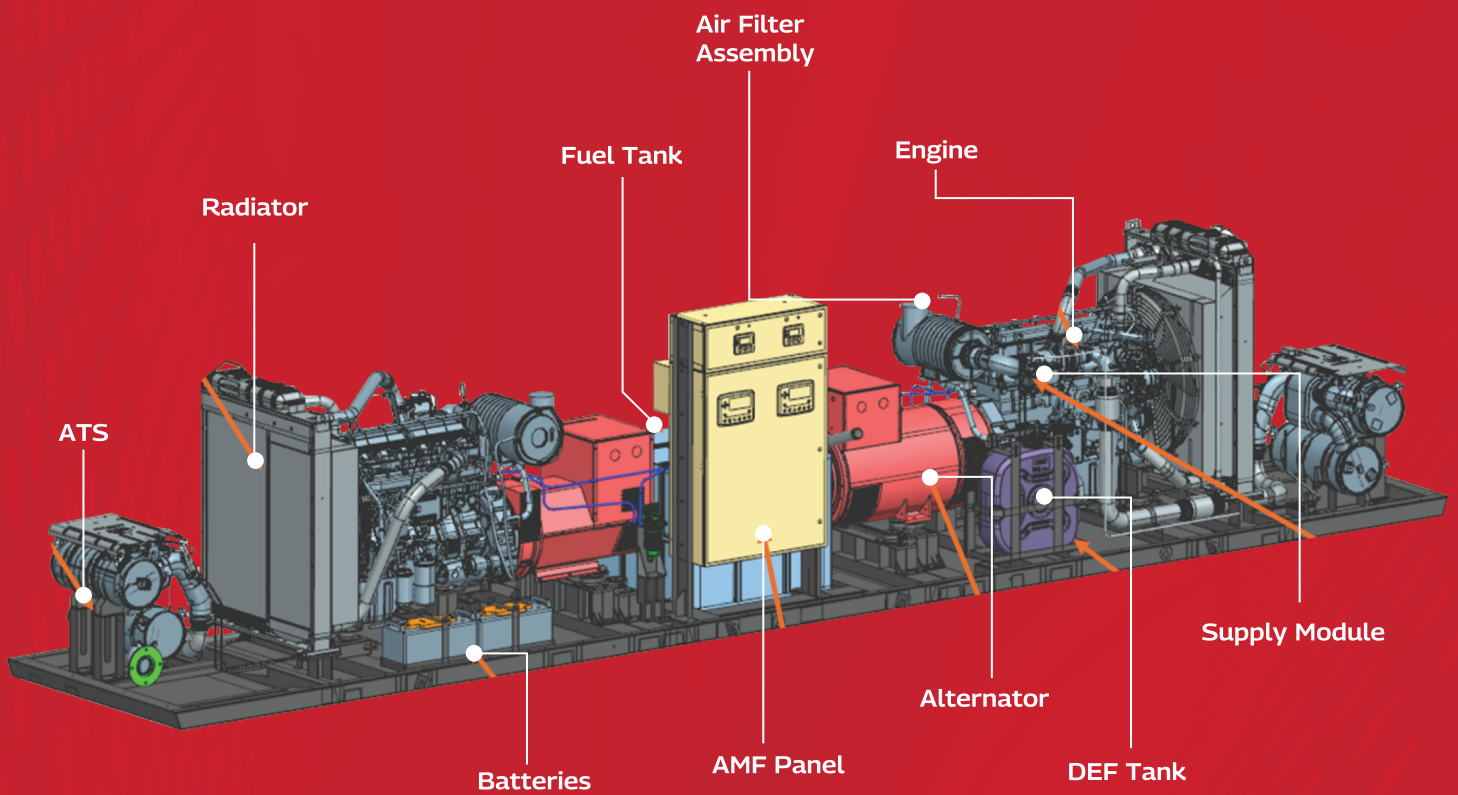

Network of 180+ Dealers
1000+ Touch Points



Mahindra & Mahindra Ltd.,
Mahindra Powerol
MHEL, 1st Floor, Gate No. 12, A-1/1, Talawade Chakan Rd,
Chakan Industrial Area,
Phase-IV, Nigoje, Maharashtra, 410501.



Toll free no. 1800 419 1999
poweroldg@mahindra.com
www.mahindrapowerol.com